

MINI STROBE-BARS



TMB-108



TMB-117



TMB-159



TSB-1812

TMB-108 LED STROBE BAR

SAE CLASS-1 MINI STROBE, LIGHT BAR AVAILABLE IN MAGNET MOUNT OR FIXED MOUNT IN MANY COLOR COMBINATIONS



SIZE: 10" x 8" x 3" (L/W/H)

**AVAILABLE CONFIGURED IN ANY COMBINATION
AND CONFIGURATION OF THE FOLLOWING COLORS:**

EXAMPLE MODEL NUMBERS:

TMB-108A: Amber
TMB-108AM: Amber with Magnets
TMB-108AC: Amber/White
TMB-108AB: Amber/Blue
TMB-108G: Green
TMB-108R: Red
TMB-108RW: Red/White
TMB-108RWB: Red/White/Blue

**ADD AN 'M' SUFFIX TO ANY PART
NUMBER FOR MAGNETIC TYPE**

TYPICAL APPLICATIONS:

- **UTILITY TRUCKS**
- **CONSTRUCTION TRUCKS.**
- **VOLUNTEER FIRE-FIGHTERS**
- **PICKUP TRUCKS.**

FEATURES:

- 6 Different, Selectable Flash Patterns.
- 18 High-Intensity LED's, 3 Per Head.
- Power Level: SAE Class-1.
- Voltage: 10 to 32 Volts DC.
- Tough Clear Polycarbonate Cover

5 Year Warranty

TMB-117 SERIES

LED STROBE BAR

SAE CLASS-1 MINI STROBE-LIGHT BAR



SIZE: 11" x 7" x 3" (L/W/H)

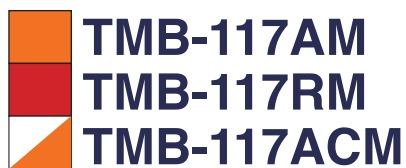

TMB-117AM

TMB-117RM

TMB-117ACM

Triton 5-Year Limited Warranty.

TYPICAL APPLICATIONS:

- **UTILITY TRUCKS**
- **CONSTRUCTION TRUCKS.**
- **PICKUP TRUCKS.**

FEATURES:

- 10 Different, Selectable Flash Patterns.
- 80 COB High-Intensity LED's.
- Power Level: SAE Class-1.
- Voltage: 10 to 32 Volts DC.
- Polycarbonate clear cover.
- Strong base magnets.
- 10ft cord with cigar plug with on/off and flash pattern switches.

AMBER LED MINI-LIGHT-BAR TMB-159 SERIES



ACTUAL SIZE: 15" x 9" x 3" (W/D/H)

RUGGED, SAE CLASS-1 360 DEGREES HIGH INTENSITY

56 High intensity LEDs
Low current draw, high lumens output 10
to 30 Volts DC operation
SAE J845 Class 1 certified

- 10 Selectable flash patterns
- Last flash pattern memory
- Shatterproof polycarbonate lens and base
- Polycarbonate aluminum-coated reflector
- 8ft Power cord
- Reverse polarity protected
- Four studs or magnet mount

AMBER FIXED MOUNT MODEL: TMB159A
AMBER MAGNET MOUNT MODEL: TMB159AM
AMBER/CLEAR FIXED MOUNT MODEL: TMB159AC
AMBER/CLEAR MAGNET MOUNT MODEL: TMB159ACM
RED MAGNET MOUNT MODEL: TMB159RM

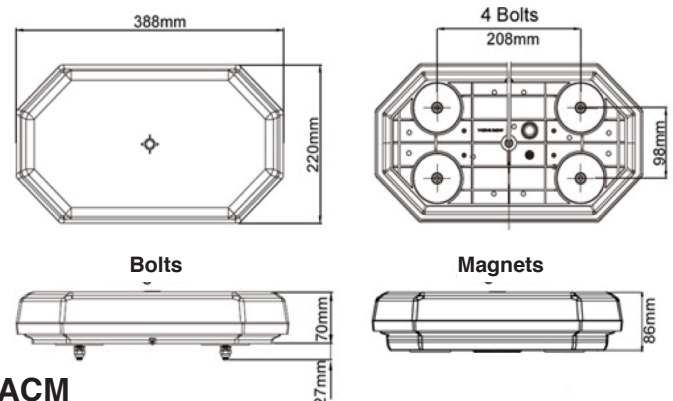
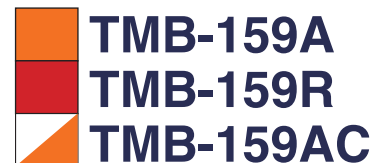

Triton 5 Year Limited Warranty

TMB-1812

18-INCH LED MINI STROBE-BAR

18" x 12" SAE CLASS-1
MINI STROBE BAR

**ADJUSTABLE SPIDER-LEGS
FOR FLEXIBLE MOUNTING CONFIGURATION.**



18" x 12" x 5" (L/W/H)

AMBER MODEL: TMB-1812A
AMBER/WHITE MODEL: TMB-1812AC

FEATURES:

- 11 Different Selectable Flash Patterns
- 38 COB High-Intensity LED's.
- Power Level: SAE Class-1.
- Voltage: 10 to 32 Volts DC.
- Base and Mounting Feet : Aluminum

TYPICAL APPLICATIONS:

- UTILITY TRUCKS
- CONSTRUCTION TRUCKS.
- PICKUP TRUCKS.

Triton 5-Year Limited Warranty.